

# WARNING:

THIS PAMPHLET  
CONTAINS

IB152

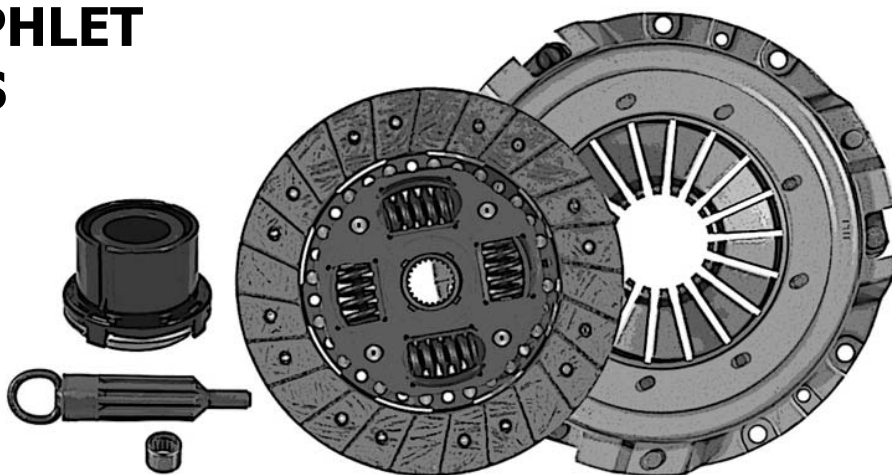

# Tech Tips

FOR APPLICATIONS SHOWN BELOW

1980-86 Jeep CJ ..... IB133

1993-98 Jeep Cherokee, Wrangler & Comanche ..... IB140

1994 Jeep Cherokee & Wrangler .....IB141

1994-2002 Dodge Ram P/U Truck  
Cummins Turbo Diesel & V10 .....IB146

1991-99 Jeep Cherokee - Wrangler .....IB165

***PLEASE READ THOROUGHLY BEFORE INSTALLATION OF  
THE COMPONENTS IN THIS SET!***

For Technical Assistance Call 1-800-258-8312

# 1980-86 Jeep CJ

IB133

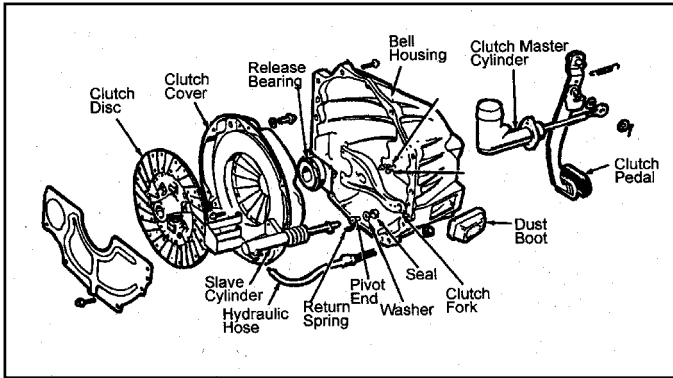

**Please be sure to inspect the slave cylinder rod plastic pivot and seal. This pivot can crack, wear and even disintegrate, which will make it impossible for the clutch to release properly. It will most likely be necessary to replace the pivot, seal and washer from your local Jeep Dealer.**

# 1993-98 Jeep Cherokee, Wrangler & Comanche

IB140

## Release Problems - Clutch Pedal Bushings Worn Out

**Please check the clutch pedal bracket assembly for signs of extreme wear:**

- > Dark color hydraulic fluid
- > Leaking master cylinder
- > Clutch pedal loose, slides from side to side.
- > Unusually hard to bleed hydraulic system.

**JEEP recommends replacing the parts shown to remedy this problem:**

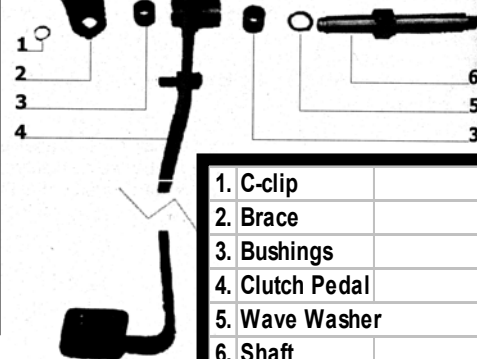

1. C-clip	J400-6471
2. Brace	5300-7885
3. Bushings	J094-6177
4. Clutch Pedal	5300-7964
5. Wave Washer	J535-1844
6. Shaft	J535-9834

## 1994 Jeep Cherokee & Wrangler

**There is marginal clearance between the slave cylinder and bellhousing which can restrict proper fork rotational movement.**

**Jeep offers a special shim, Part Number 4797072 that relocates the slave cylinder enough to allow the fork to make it's proper rotation.**

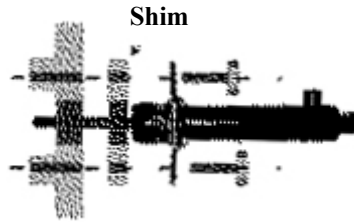

**For additional info, see Chrysler Tech Bulletin 06-03-94.**

## 1994-2002 Dodge Ram P/U Truck Cummins Turbo Diesel & V10

**It is easy to improperly install the clutch fork in these vehicles. This will cause a noise from the clutch pedal when depressed.**

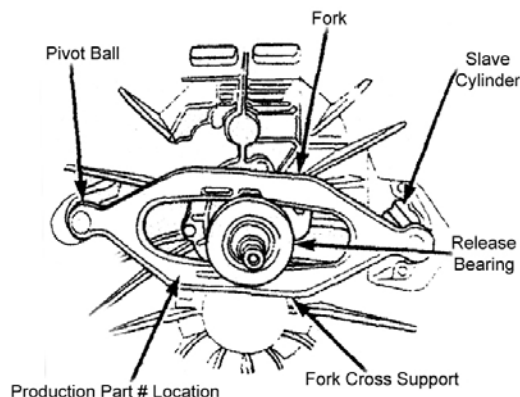

**To prevent this, locate the production part number on the clutch fork and install it on the same side of the input shaft as the pivot ball.**

# 1991-99 Jeep Cherokee - Wrangler

## Hydraulic Clutch Assembly

### PLEASE READ BEFORE INSTALLING

- 1.) Do not cut or remove straps. Piston seal damage may result. The straps are designed to break when the clutch is first actuated.
- 2.) Do not push or pull on the bearing. Piston seal damage may result.
- 3.) Use only new, clean, DOT-3 Brake Fluid.
- 4.) Bending tubes is not necessary. Do not remove tubes or snap pins. Leakage may result.
- 5.) Keep unit clean. Do not drop.
- 6.) Use grommets to protect tubes.
- 7.) Do not clean or grease this unit.
- 8.) Use care when tightening flare nuts so the threads are not damaged.
- 9.) Be sure to use the pin and retaining nut enclosed. Do not re-use existing pin and nut.
- 10.) Bleed system. Air in system prevents disengagement.
- 11.) If bearing and piston assembly is pushed out of the housing, DO NOT reassemble. Replace the unit.

Failure to heed the above recommendations may result in reduction of assembly life. Please consult the manufacturer's shop manual for additional procedures and specifications.

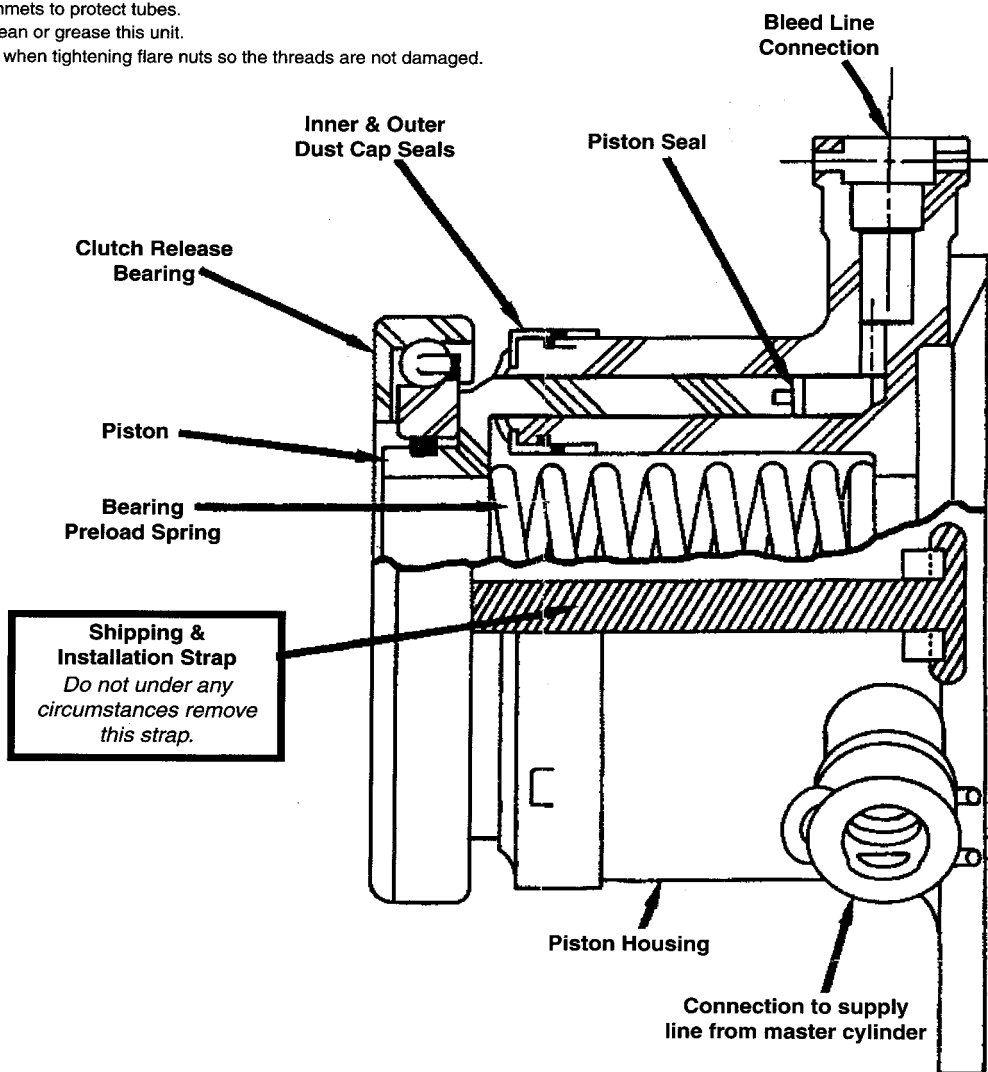

**Caution: Do not under any circumstances push or pull Clutch Bearing Assembly.**